

BACK EDGE REINFORCEMENT SPINE

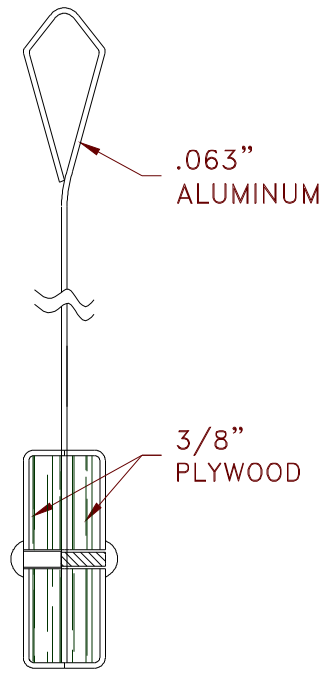

SECTION "AA" OF DOOR

SPECIFICATIONS:

DOORS SHOWN AS ALUMINUM SHEET STYLE SERVICE DOORS, DOUBLE ACTING, SHALL BE MODEL SD-2000 CAFE DOORS AS MANUFACTURED BY CHASE INDUSTRIES, INC., CINCINNATI, OHIO, TO FIT DOOR OPENING _____ WIDE BY _____ HIGH.

DOOR SHALL BE CONSTRUCTED OF .063" THICK ALUMINUM WITH ANODIZED ALUMINUM FINISH, BOTH SIDES.

DOOR TO HAVE 1" THICK x 2.5" WIDE BACK EDGE REINFORCEMENT SPINE. BACK EDGE SPINE SHALL HAVE PLYWOOD CORE AND BE CLAD WITH PROPER ALUMINUM TO MATCH DOOR BODY.

COMPLETE WITH CHASE GRAVITY-OPERATED HINGING SYSTEM WITH 5/8" DIAMETER STEEL HINGE PIN AND 1" DIAMETER DELRIN CAM. BOTH TOP AND BOTTOM HINGES HAVE 3/16" THICK STEEL ANGLE AND MOUNT DIRECTLY THROUGH DOOR BODY.

NO WINDOW (VISION PANEL)
NO IMPACT PLATES

BUMPER OPTIONS (BOTH SIDES ONLY):
 PVC STRIP (SPECIFY COLOR) _____ ALUM. STRIP (SPECIFY LOCATION) _____

MODEL # SD2000, CAFE BIPARTING SHEET STYLE SERVICE DOOR

©COPYRIGHT 2000 CHASE INDUSTRIES, INC. SPECIFICATIONS SUBJECT TO CHANGE WITHOUT NOTICE.
 1 800-543-4455
 www.chasedoors.com

CUSTOMER INFORMATION:

 Chase Doors World's Leading Manufacturer Of Traffic Doors Cincinnati Ohio, and Redmond Oregon Phone Toll Free: 1-800-543-4455		DATE: 7/21/00	CHASE APPROVAL
		FORM # SD4014	REV. A