



Chase Doors

World's Leading Manufacturer of Traffic Doors

Cincinnati Ohio, and Redmond Oregon • Phone Toll Free: 1-800-543-4455 • Fax: 1-800-285-0126 • www.chasedoors.com

Canebolt Installation Instructions

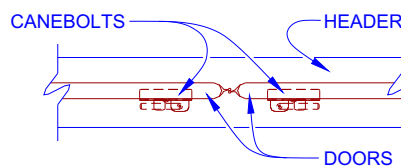
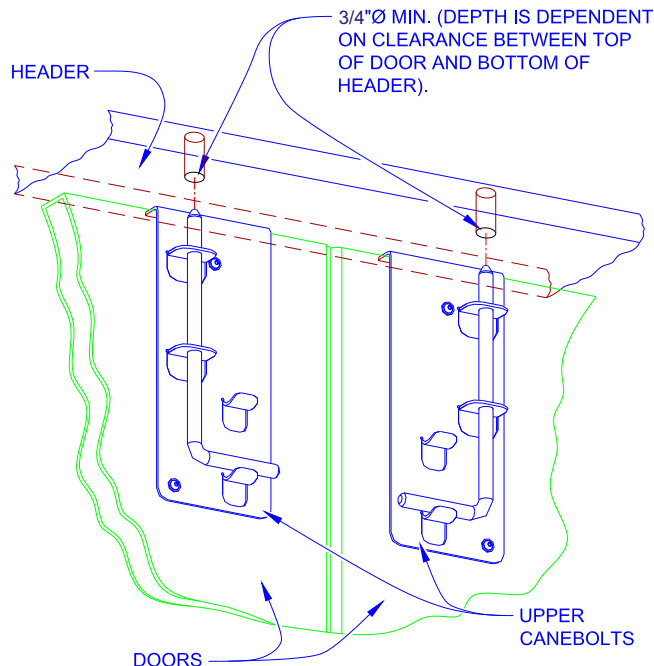

CLOSED POSITION

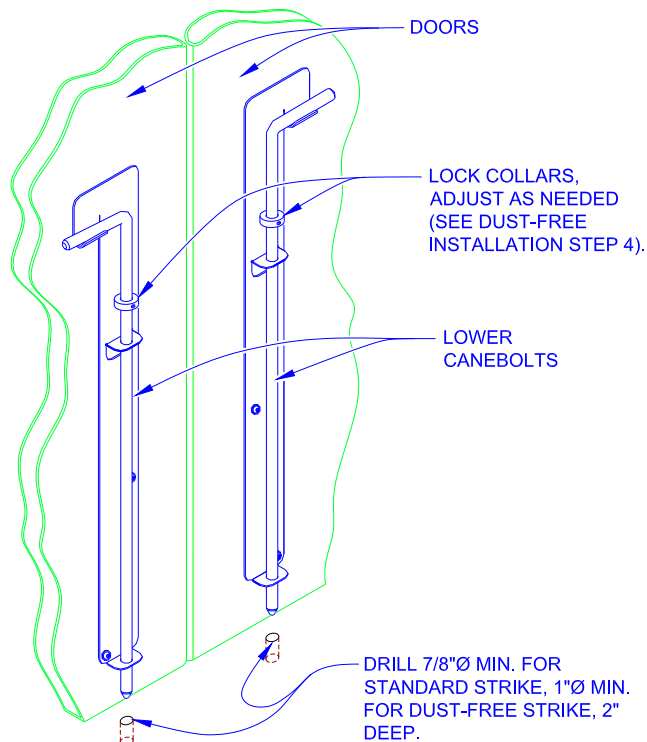

UPPER CANEBOLT INSTALLATION STEPS

NOTE: IF YOU ARE INSTALLING CANEBOLTS AFTER THE TOP SEAL HAS BEEN MOUNTED REFER TO "DETAIL A-1" BEFORE PROCEEDING.

1. WITH DOORS IN THE FULLY CLOSED POSITION (SEE DRAWING ABOVE RIGHT), RAISE CANEBOLTS UNTIL THEY CONTACT HEADER. MARK THE POINT OF CONTACT (A SMALL DAB OF GREASE ON THE TIP OF THE CANEBOLT WORKS WELL). MARK THE ACTUAL POINT OF DRILLING WITH A CENTER PUNCH.
2. DRILL A 3/4" Ø (MIN) HOLE AT EACH MARK FOR CANEBOLT ANCHORING.
3. CLOSE DOORS AND RAISE CANEBOLTS TO THE LOCKED POSITION TO CHECK DEPTH OF HOLES. IF NECESSARY, DRILL HOLES DEEPER UNTIL CANEBOLTS LIFT AND LOCK FREELY.

LOWER CANEBOLT INSTALLATION STEPS

STANDARD STRIKE

1. WITH DOORS IN THE FULLY CLOSED POSITION, MARK THE FLOOR WHERE THE CANEBOLT MAKES CONTACT WHEN LOWERED.
2. DRILL A MINIMUM 7/8" Ø X 2" DEEP HOLE AT THE MARKED POINT.
3. DRIVE THE ALUMINUM SLEEVE INTO THE HOLE.

DUST-FREE STRIKE

1. WITH DOORS IN THE FULLY CLOSED POSITION, MARK THE FLOOR WHERE THE CANEBOLT MAKES CONTACT WHEN LOWERED.
2. DRILL A MINIMUM 1" Ø X 2" DEEP HOLE AT THE MARKED POINT.
3. AFTER THE HOLE IS DRILLED, EPOXY AND TAP DUST-FREE STRIKE INTO PLACE.
4. ADJUST THE LOWER CANEBOLT BY SETTING THE CANEBOLT LOCK COLLAR SO THAT THE LOWER CANEBOLT DOES NOT COMPLETELY COMPRESS THE SPRING WITHIN THE STRIKE.

CUT THE TOP SEAL IN TWO DIRECTIONS PERPENDICULAR TO EACH OTHER. A TOP SEAL WITH A PLASTIC EXTRUSION MAY NEED DRILLED AT THIS AREA. BE SURE THAT THE CANEBOLT MOVES FREELY THROUGH THE CUT TO THE ANCHORING POINTS ABOVE.

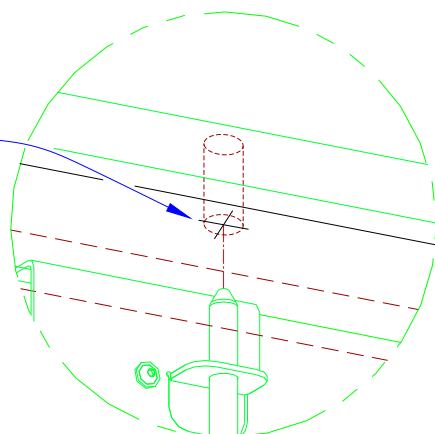

DETAIL "A-1"