

Installing on Slanted Floors

Supplemental Instructions for "Durulite Installation Instructions"

MARKING JAMB FOR HARDWARE

NOTE: BEFORE PROCEEDING, MEASURE BOTH SIDES OF JAMB TO DETERMINE THE "SHORTER SIDE A" AND THE "LONGER SIDE B" (SEE FIGURE 1).

IMPORTANT: THE SHORTER SIDE OF THE OPENING AS DETERMINED ABOVE **MUST NOT** BE SHORTER IN DISTANCE THAN THE OPENING HEIGHT GIVEN ON ORDER, REFER TO "PREPERATION" PORTION OF THE "DURULITE INSTALLATION INSTRUCTIONS".

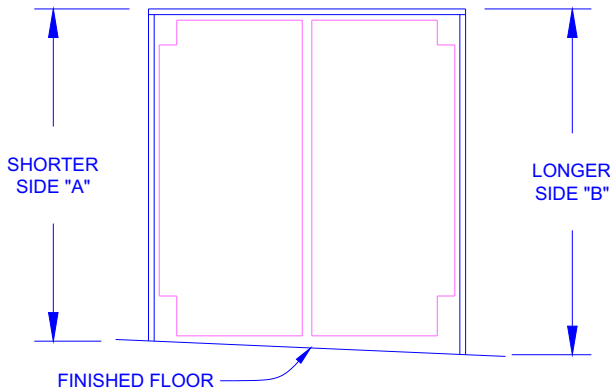

FIGURE "1"

N.T.S.

1. BEGINNING WITH THE SHORTER SIDE "A" (SEE FIGURE 1), PROCEED WITH STEP A OF THE "DURULITE INSTALLATION INSTRUCTIONS" (DO NOT REMOVE TEMPLATE AT THIS TIME).
2. PRIOR TO REMOVING TEMPLATE, CAREFULLY MEASURE FROM THE BOTTOM OF THE HEADER TO THE TOP OF THE TEMPLATE (SEE FIGURE 2).
3. CENTER TEMPLATE ON "LONGER SIDE B" AND ADJUST THE TOP OF TEMPLATE TO MEASUREMENT DETERMINED IN "STEP 2" (SEE FIGURE 3). FASTEN TEMPLATE TO JAMB WITH TAPE AND CONTINUE WITH STEP A OF THE "DURULITE INSTALLATION INSTRUCTIONS".
4. TRIM LOWER SEAL AT FINISHED FLOOR LEVEL AS NEEDED.

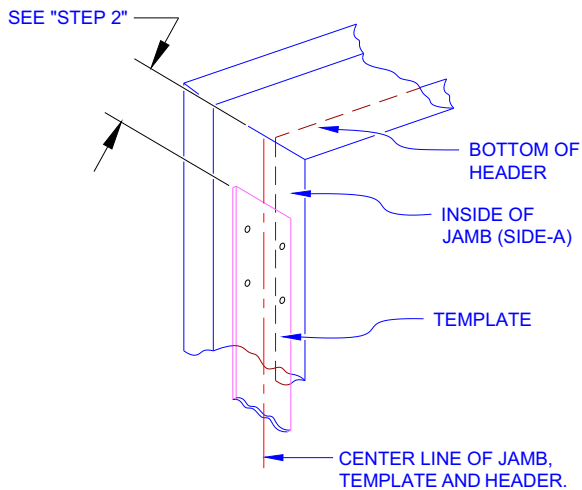

FIGURE "2"

N.T.S.

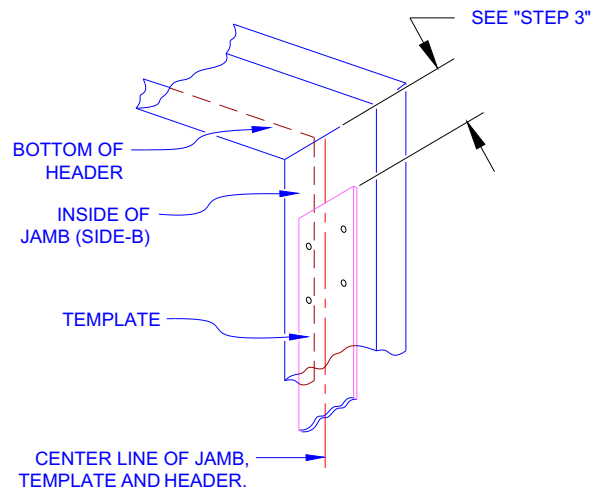

FIGURE "3"

N.T.S.